

Reverse Boom Floor Crane 600 Series



Reverse Boom Floor Crane



Reverse Boom Floor Cranes

Useful for supplying materials to production areas not serviced by overhead cranes. This counterweight design allows crane to be close to item being lifted without obstructions by the legs. Equipped with roller bearing wheels, swivel wheel foot brakes, manual pump, adjustable chain and hook, safety pins, push handle and counterweight. RC10 and RC20 models fold up for compact storage and transportation.

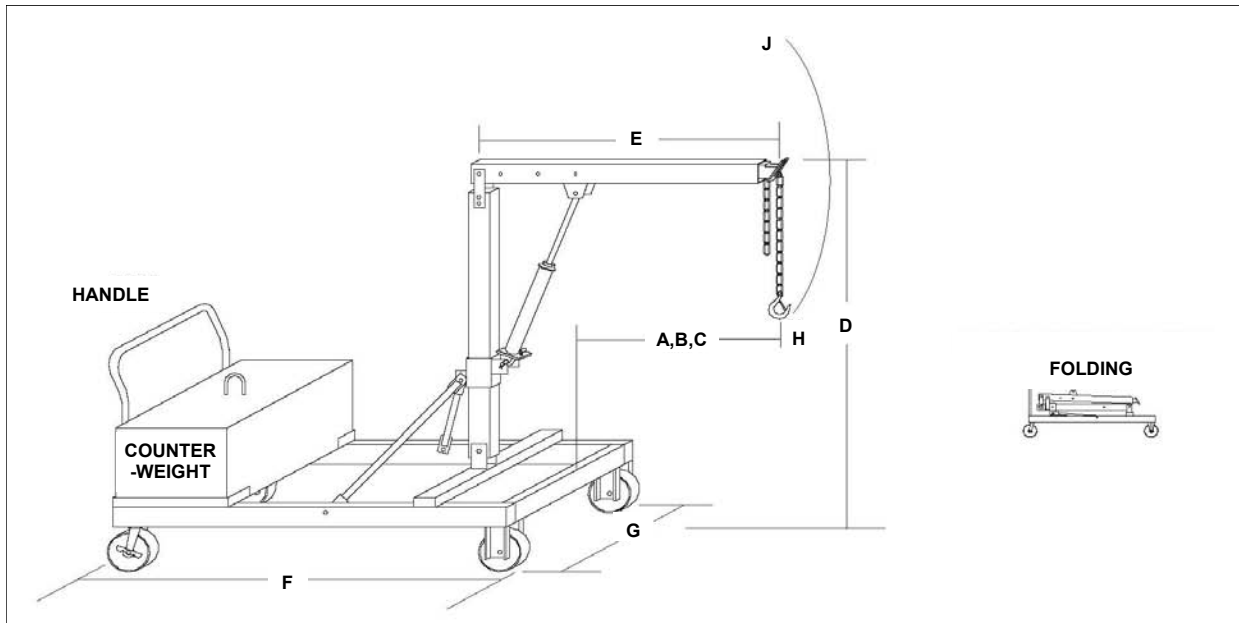

SPECIFICATIONS

MODELS	CAPACITY A LBS	CAPACITY B LBS	CAPACITY C LBS	COUNTER WEIGHT LBS	SHIPPING WEIGHT LBS	REPLACEMENT PUMP	PUMP (SEALS) WEAR KIT
600-10	1,000	770	650	650	1050	LRJ3-3	LRJ3-3RK
600-20	2,000	1,280	1000	1300	1750	LRJ3-3	LRJ3-3RK
600-30	3,000	2,000	1500	1950	2450	LRJ5-3	LRJ5-3RK

MODEL	REACH A INCHES	REACH B INCHES	REACH C INCHES	MAST D INCHES	BOOM E INCHES	BASE F INCHES	BASE G INCHES	MAX LOW H	MAX HIGH J
ALL MODELS	36	43	50	78	57	72	30	32	105

If your capacities are not shown with our standard designs, custom designs can be engineered to satisfy specific needs.